



Bronze High Lift Safety Valves

Test Lever - Screwed or Flanged Connections

GRESSWELL G100 HIGH LIFT SAFETY VALVES

Side Outlet discharge with test lever. These valves are used with compressible media, mainly steam systems to prevent safe pressures being exceeded.

Also available with stainless steel trim.

SIZE RANGE

DN	15	20	25	32	40	50
in	½"	¾"	1"	1¼"	1½"	2"

PIPE CONNECTIONS

INLET: Threaded 'G' (BSP) Male to BS EN ISO 228/BS 2779

OUTLET: Threaded 'Rp' Parallel Female to BS 21/BS EN 10226/ISO 7

Alternative thread standards, e.g. 'R' x 'Rc' (BSPT) or ANSI B1.20.1 (NPT) are available upon request.

FLANGED: Most flange standards can be accommodated, e.g. BS EN 1759 (Class designated), BS EN 1092 (PN designated) or BS 10 (Table designated) - please specify.

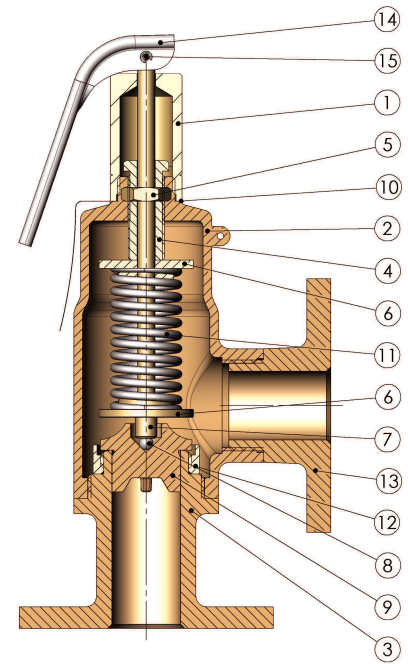

STANDARD SPECIFICATION

No.	Component	Material	No.	Component	Material
1	Dome Top	Cu Alloy BS EN 12164 CW614N	8	Ball	St. Steel AISI 420
2	Body	Cu Alloy BS EN 1982 CC491K	9	Valve	Cu Alloy BS EN 12165 CW602N
3	Base	Cu Alloy BS EN 1982 CC491K	10	Label	Metallised Polymer
3SS	St. St. Base	ASTM A 351/A 351M CF8M	11	Spring	St. Steel BS2056 302 S26
3FL	Inlet Flange	Cu Alloy BS EN 1982 CC491K	12	Blowdown Ring	Cu Alloy BS EN 1982 CC491K
4	Adjusting Screw	Cu Alloy BS EN 12164 CW614N	13	Outlet Flange	Cu Alloy BS EN 1982 CC491K
5	Lock Nut	Cu Alloy BS EN 12164 CW614N	14	Easing Lever	Stainless Steel
6	Spring Plate	Cu Alloy BS EN 12164 CW614N	15	Lever Pin	Stainless Steel
7	Spindle	Cu Alloy BS EN 12164 CW614N			

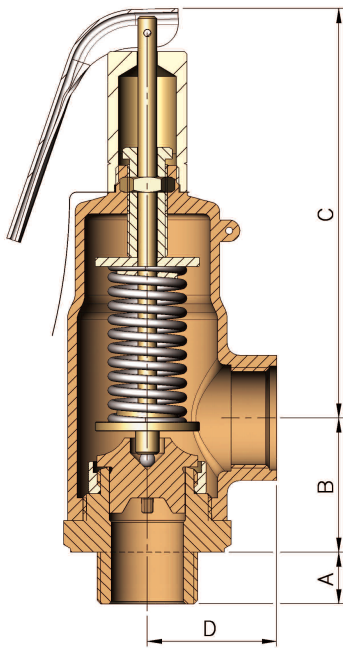

FEATURES & BENEFITS

Gresswell Valves are quality assurance approved to BS EN ISO 9001: 2008. Certificate No. 10002498.

Manufactured in accordance with BS 6759 Parts 1 & 2 and compliant with BS EN ISO 4126 Part 1 with full Cat IV PED approval.

The G100 range of valves are ideal for handling compressible material but it must be noted... **they are not suitable for liquids.**

Clear operating and maintenance instructions are supplied with each despatch.

Generally in accordance with BS6759 Parts 1 & 2.

See leaflet Ref: DC G100 for Discharge Capacities.

TESTING

All Gresswell Relief Valves are given a hydraulic seat tightness test before leaving the factory and the adjustment range is clearly marked.

All valves are supplied pre-set.

Flanged valves are pressure tested to ensure soundness of joints.

Special tests or witness testing can be arranged at extra cost.

DIMENSION CHART

Size	A	B	C	D	Weight (kg)
DN15	16	35	106	33	0.6
DN20	16	36	114	40	0.8
DN25	17	47	130	48	1.6
DN32	22	56	172	54	2.2
DN40	24	57	170	57	3
DN50	30	68	180	73	4

All dimensions in millimetres (mm). Flange dimensions vary according to specification (available upon request).

SPRING/PRESSURE RANGES at up to 225°C (437°F)

Type	Colour Code	Bar.g	p.s.i.g
A	Red	0.2 - 0.5	3 - 7
B	Blue	0.5 - 0.8	7 - 12
C	Green	0.8 - 1.4	12 - 20
D	Yellow	1.4 - 2.4	20 - 35
E	White	2.4 - 4.1	35 - 60
F	Black	4.1 - 5.9	60 - 85
G	Brown	5.9 - 8.6	85 - 125
H	Purple	8.6 - 12.1	125 - 175
J	Grey	12.1 - 15.5	175 - 225
K	Orange	15.5 - 19.0	225 - 275
L	Red & Black	19.0 - 20.7	275 - 300



GRESSWELL VALVES

Halesfield 21, Telford, Shropshire, TF7 4NX

Tel: 01952 580946 Fax: 01952 582546

email: sales@gresswellvalves.com

www.gresswellvalves.com